



sunpro[®]

gas boosted solar specifications

easyinstall

*standard half inch gas connection,
meaning lower installation costs*

mainspressure

solar hot water provided at mains pressure



*Gas boosted solar is the most efficient
type of hot water system available*



sunpro[®] solar gas

Why you should choose a Dux Sunpro[®] solar gas system

- Gas boosted solar is the most efficient type of hot water system available
- Low megajoule consumption burner, requiring only half inch gas pipe
- Mains pressure hot water, unlike most other gas boosted solar systems on the market
- Intelligent patented Hotlogic[®] controller optimises lowest cost energy supply
- Patented Panel Management System protects the collectors from overheating in summer and provides frost protection in winter
- Zero water wastage during start-up cycle
- High efficiency polyurethane insulated storage tank



STC Table – Gas Boosted Systems

PRODUCT CODES: DN15DT2DC, DL15DT2DC	STC ZONE			
COLLECTORS	1	2	3	4
2	38	42	35	31



Calculations are based on Dux 2AP style collector. STCs calculations for electric boosted units are based on Continuous Tariff. STC values are subject to change without notice and are correct at time of printing.

SPECIFICATIONS	315 LITRE
Gas Consumption (MJ/hr)	45*
Gas type	Natural/LPG
Net weight empty (kg)	112
Cold water socket size	RP ³ / ₄ "/20mm
Gas pipe size	RP ¹ / ₂ "/15mm
Relief valve pressure (kPa)	1000
TANK DIMENSIONS	
A Tank height (mm)	1754
B Tank diameter (mm)	617
C Tank depth (incl cover) (mm)	835

* ±5%

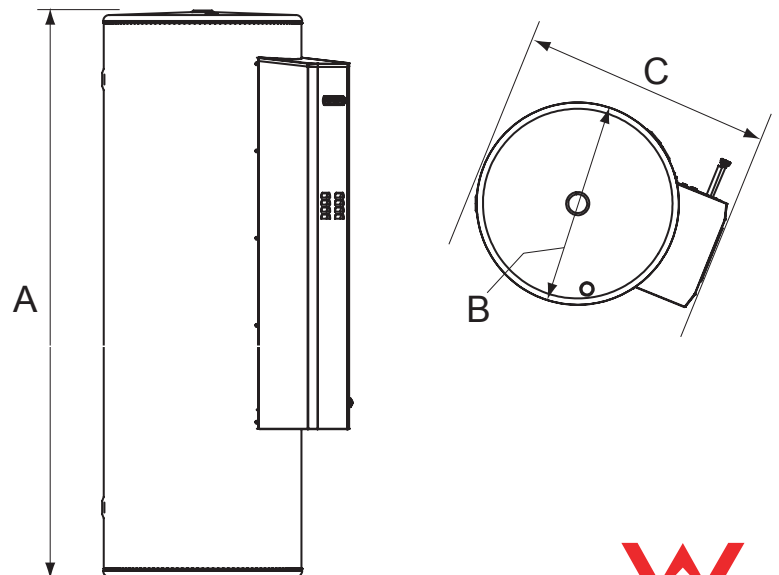

Did you know

As a guarantee of performance all Dux[®] solar water heaters are supplied with a genuine Reliance[®] brand Dux[®] solar tempering valve. These valves have been adjusted to Dux specification to ensure maximum hot water delivery.



©Dux Manufacturing Limited ABN 19 077 879 844. Lackey Rd, PO Box 209 Moss Vale, NSW 2577
The information supplied was correct at time of printing. Specification and materials may change without notice.
© and ™ indicate trademarks of Dux Manufacturing Limited. Dux Manufacturing Limited is part of a publicly listed Australian company.

