





# 5 STAR RHEEM 265/295 GAS STORAGE WATER HEATER

		2 - 5	272 or 302L	5 YEAR	50°C LIMITED MODELS
GAS	5 STAR	PEOPLE	FIRST HOUR CAPACITY	WARRANTY <sup>1</sup>	



## FEATURES

- **5 Star energy efficiency** – uses less gas than 3 or 4 Star water heaters, so saves on home gas bills
  - **Mains pressure** at multiple taps – to service multiple hot water demands at once
  - **Strong recovery** – to have you back in hot water fast
  - **272L or 302L first hour capacity** of hot water
  - **Compact size** – 485mm diameter, for easy replacement of existing 3 star gas water heaters
  - 5 Year Warranty<sup>1</sup>
- **RheemPlus® 265/295 models available**
    - 50°C Temperature limited
    - Adjustable to deliver higher temperatures (complying with AS 3498)
    - No tempering valve required<sup>2</sup>

## WHY CHOOSE RHEEM GAS STORAGE HOT WATER?

- Designed for Australia's tough conditions, using over 70 years of experience
- Capacities to suit family sizes and hot water requirements
- Fast hot water recovery
- Mains pressure water delivery for steady, hot and strong hot water
- Full technical support through Rheem's National Service Network
- Available to suit Natural Gas or Propane



COMES ON STEADY, HOT AND STRONG

INSTALL A





# 5 STAR RHEEM 265/295 GAS STORAGE WATER HEATER

## MAINS PRESSURE HOT WATER WHEN YOU NEED IT

Mains pressure gas storage water heaters are your guarantee of consistent hot water. You can be sure of a strong flow of hot water, even to multiple taps at once.

Rheem's modern design complements any home. And Rheem 5 Star energy efficient Gas Storage water heaters are good for the environment.

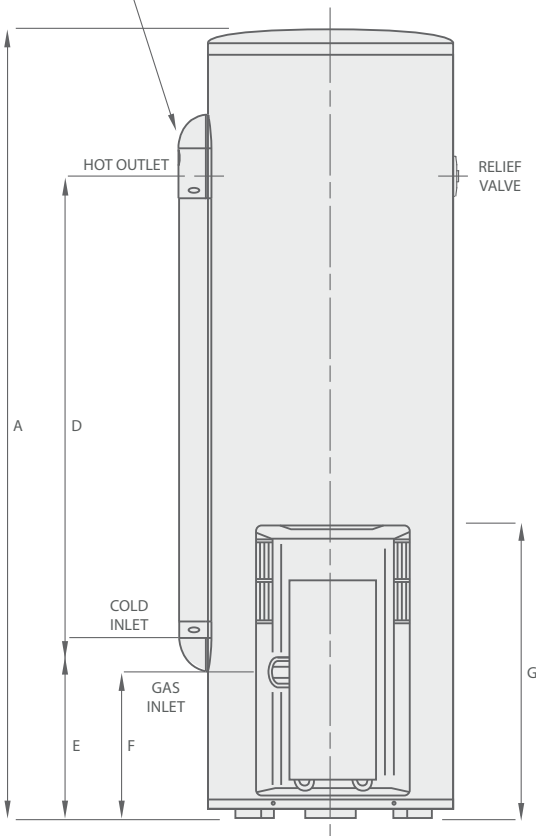
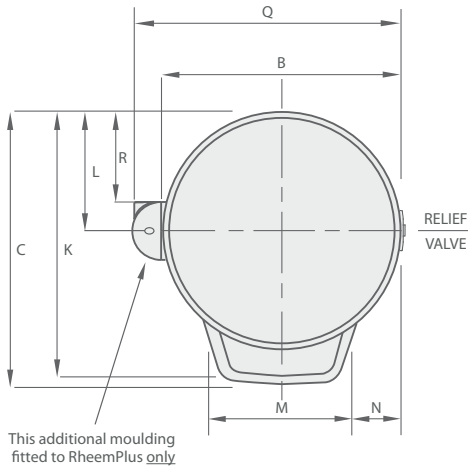

MODEL	RHEEM 5 STAR		
	265	295	
Rheem 5 Star	350265	350295	
RheemPlus® 5 Star (50°C limited) <sup>2</sup>	354265	354295	
<b>Number of People</b>			
Moderate Climate	2-4	3-5	
Cool Climate	2-3	3-4	
Warranty <sup>1</sup>	5 years	5 years	
Gas Type	Natural Gas /Propane		
Gas Energy Rating	5.3	5.3	
Storage Capacity	Litres	130	160
Recovery Rate @ 45°C	L/hr	142	142
First Hour Capacity	Litres	272	302
Hourly Gas Consumption Natural Gas	MJ	30	30
<b>Dimensions</b>			
A	mm	1622	1922
B	mm	485	485
C	mm	556	556
D	mm	988	1213
E	mm	328	409
F	mm	298	298
G	mm	600	600
K	mm	520	520
L	mm	240	240
M	mm	297	297
N	mm	97	97
Q (RheemPlus® only)	mm	545	545
R (RheemPlus® only)	mm	182	182
Weight Empty	kg	75	85
Relief Valve Setting	kPa	1400	1400
Expansion Control Valve (ECV) Setting	kPa	1200	1200
<b>Max. Water Supply Pressure</b>			
with ECV	kPa	960	960
without ECV	kPa	1120	1120
Water Connection	RP 3/4/20	RP 3/4/20	RP 3/4/20
Gas Connection	RP 1/2/15	RP 1/2/15	RP 1/2/15

<sup>1</sup> Warranty: 5 Years on Cylinder, 3 Years Labour on Cylinder, 1 Year Parts & Labour warranty on all other components for Domestic (non-Commercial) installations.

<sup>2</sup> 50°C factory pre-set models supply hot water at a maximum 50°C at all outlets in accordance with AS 3498. Some applications may require tempering, refer to AS 3500.4.

\* Registered Trademark of Rheem Australia Pty Ltd.

Materials and data are subject to change without notice.



The Australian Gas Association



Quality ISO 9001



AS 3498 WMKA00153

### Rheem Australia Pty Ltd.

1 Alan Street, Rydalmere, New South Wales 2116, Australia  
PO Box 6, Rydalmere, New South Wales 2116, Australia.

INSTALL A

